

TOCR01

FLUSH MOUNT 360° MICROSENSITIVE OCCUPANCY DETECTOR

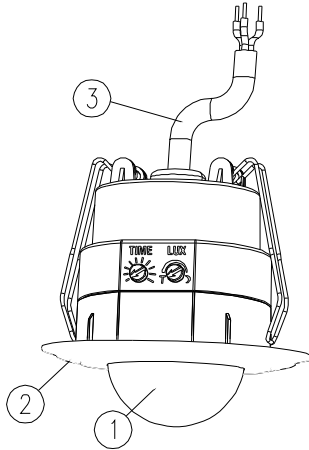

- Lens
- , Main Body
- f Power Cord

INTRODUCTION

The use of occupancy detectors in commercial and industrial applications can significantly reduce energy usage reducing both energy costs and helping the environment.

The TOCR01 360 degrees MICROSENSITIVE flush mount OCCUPANCY DETECTOR uses passive infrared sensors (PIR) which react to changes in temperature emitted by the slight motion of persons or objects passing through its detection area. The PIR sensor automatically operates the connected load when an area is occupied. After a preset time on non-activation (when an area is vacated) the load will be switched off. In addition the built in photocell takes natural light (daylight) into account when determining its activation.

Note : Read this entire manual before you start to install the system.

SAFETY PRECAUTIONS

- I Do not install when it may be possible for water to access the fitting.
- I Be sure to switch off power source before installing.
- I Make sure that the power wiring comes from circuit with an external miniature circuit breaker not higher than 16A for the short circuit protection or a suitable fuse.
- I The unit should not be installed on the wall. (FIGURE 1)

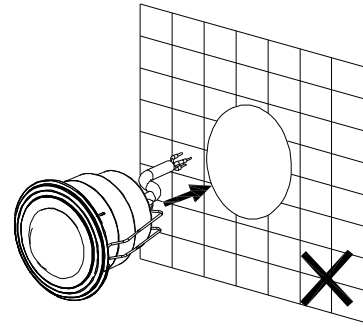

FIGURE 1

IMPORTANT

Some local building codes may require installation of this product by a qualified electrician.

Check your local codes as they apply to your situation. If the house wiring is of aluminum, consult with an electrician about proper wiring methods.

Before proceeding with the installation, TURN OFF THE POWER TO THE LIGHTING CIRCUIT AT THE CIRCUIT BREAKER OR FUSE BOX TO AVOID ELECTRICAL SHOCK.

CHOOSING A MOUNTING LOCATION

- I Avoid aiming the motion sensor at heating vents, air conditioners or objects which may change temperature rapidly.
- I Do not allow sunlight to fall directly on the front of unit.

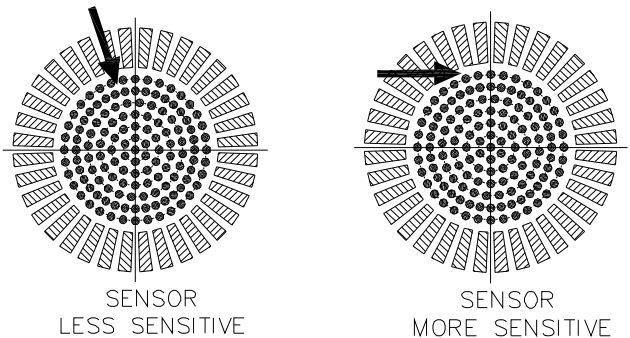

FIGURE 2

INSTALLATION

The unit has a sensing angle of 360°. It detects micro movement within a 6m diameter (sitting zone) and can detect general movement up to 10m diameter at a mounting height of 2.5 meters. (FIGURE 3)

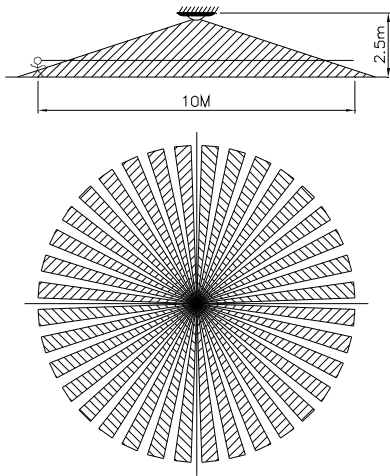

FIGURE 3

SCHEMATIC

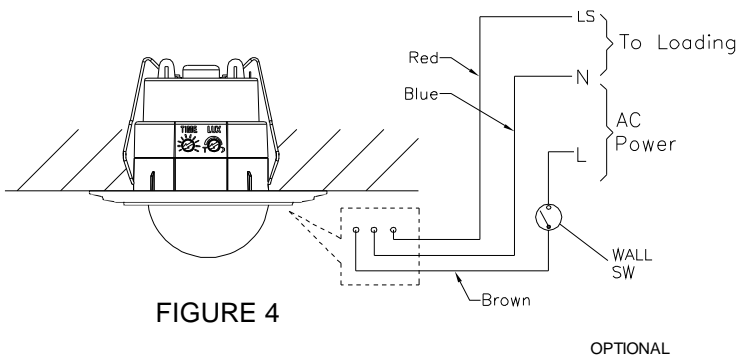

FIGURE 4

WIRING INSTRUCTION

- (1) Switch off the power source or wall switch.
- (2) Strip approximately 6-8mm insulating part of the wires from the terminal block.
- (3) The connection of all power cords is at your disposal. The power cord of "LS" and "N" mark is to be connected to any light fixture you have. (FIGURE 5)

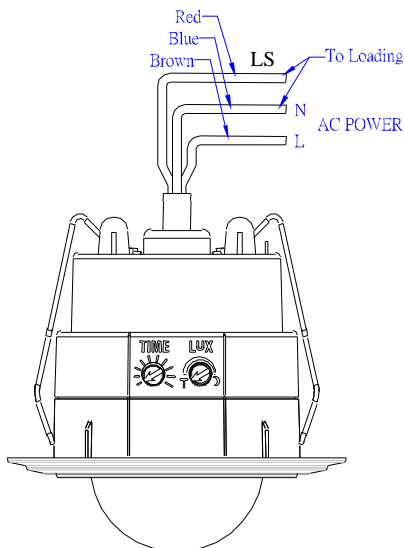

FIGURE 5

- (4) In order to install the sensor to the ceiling, drill a diameter of 65mm round hole on the ceiling. Wedge the main body into the round hole directly. (FIGURE 6)

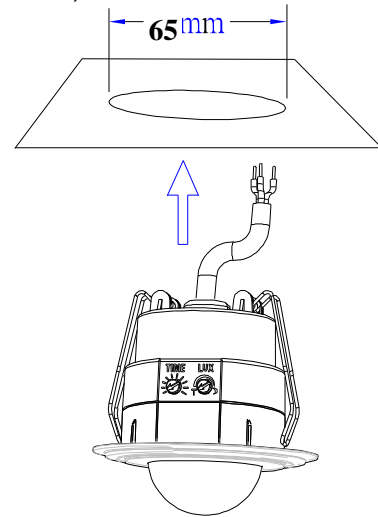

FIGURE 6

IMPORTANT: DO NOT PULL THE SPRINGS AWAY FROM THE BODY, THIS WILL DAMAGE THE SPRING TENSION AND RENDER THE WARRANTY INVALID

SETTING THE LIGHTING SYSTEM

(1) TEST MODE

- n Turn the Lux control and the Time control counter-clockwise to the edge - the TEST position. (FIGURE 7)

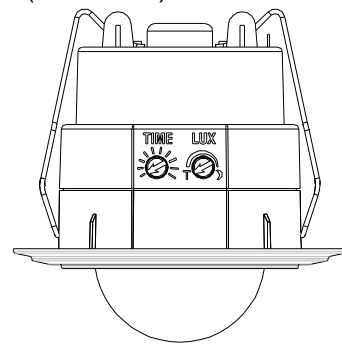

FIGURE 7

- n Turn the power supply switch on, the light will turn on immediately and wait for about 1 minute to warm up the unit. After warming-up time is expired and the light goes off, you may make a walk test and the light will turn on. This confirms that the wiring was done properly and that the light is working.
- n Walk through the coverage area. The light will turn on for about 5 seconds when motion is detected and turn off shortly after motion stops. Wait for the light to turn off before moving again

to test the sensor.

(2) SETTINGS

n TIME ADJUSTMENT

The TIME adjustment controls how long the light will stay on after motion has been detected.

Adjust the TIME Control Knob clockwise to increase the turn-off time (40 minutes maximum) or counter-clockwise to decrease the turn-off time (5 seconds minimum). (FIGURE 8) There are ten selections for time adjustment (from MIN to MAX) -- 5, 10, 20, 40, 80, 160 second and 5, 10, 20, 40 minute.

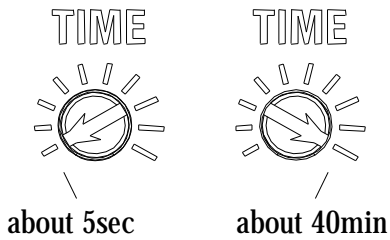

FIGURE 8

n LUX ADJUSTMENT

The LUX adjustment determines at what light level the light will start operating when you set the sensor to the AUTO MODE.

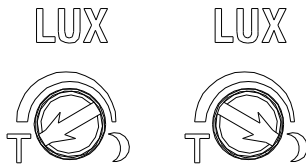

FIGURE 9

Provisionally turn the LUX Control Knob to the edge clockwise at the moon (dusk) position. (FIGURE 9) In this provisional setting mode, the Motion Sensor remains inactive during daylight. At dusk when you find it is the LUX level you desired for operation, simply set the LUX control knob to the position that you tried satisfactorily.

OPERATION

n Automatic Operation

When the sensor detects motion, the light automatically turns on. The built-in photocell turns the sensor off and on according to the light level selected by the LUX adjustment.

TROUBLESHOOTING

Light does not turn on

- I Confirm that you have made a correct "wiring connection".
- I Make sure that the bulbs have not burned out.

Light remains on
I Make sure the wiring connection is correct.
I Check if the TIME setting is correct.
Others
I The specification of protective shield shall consult to local service agent.

SPECIFICATIONS

Power Requirement	AC 230V / 50Hz
Lighting Load	Max. 8A Incandescent or Max. 6A Fluorescent
Detection Angle	Up to 360° at 25°C at 2.5m height
Detection Distance	Up to 3m radius at 25°C at 2.5m height MICROMOVEMENT Up to 5m radius at 25°C at 2.5m Height general movement
Mounting Height	Recommended 2.2 ~ 3.0m Ceiling Mount
Wall Switch Control	Auto/Off
Time Adjustment	Approx. 5 seconds to 40 minutes (5, 10, 20, 40, 80, 160 second & 5, 10, 20, 40 minute)
Lux Adjustment	Approx. 30 ~ 200 Lux & test mode
Warm Up Time	About 1 min
Protection Class	Class II
Protection Degree	IP44 WHEN INSTALLED
Safety	CE, GS

**** Specifications are subject to change without prior notice.**



A501111209R

Warning:

Do not dispose of electrical appliances as unsorted municipal waste, use separate collection facilities.

Contact your local government for information regarding the collection systems available.

If electrical appliances are disposed of in landfills or dumps, hazardous substances can leak into the groundwater and get into the food chain, damaging your health and well-being.